

Varenummer: 2301044321
 Beskrivelse: E+G Håndsving
 MT.100+IR-A12

Mål

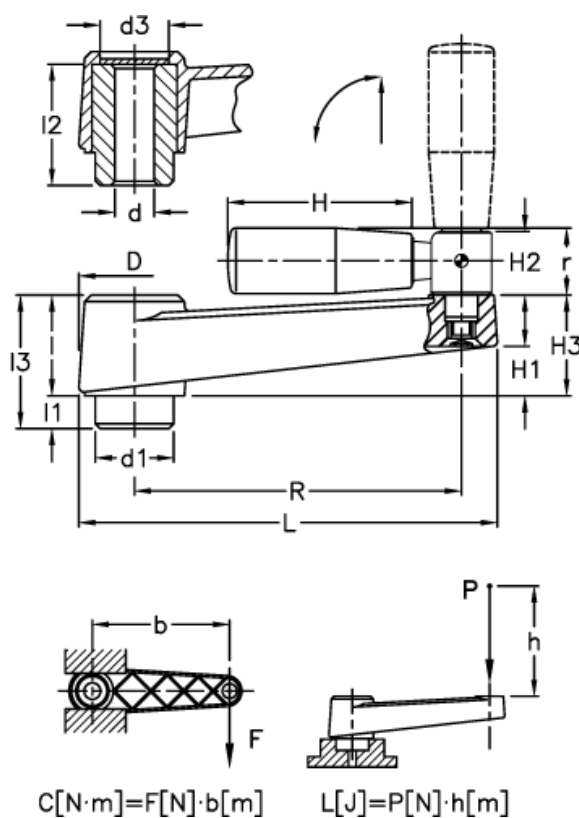

C (N*m) = 200	H3 = 31	R = 100
D = 34	l = 30	
d1 = 24	L = 128	
d3 = 21	L (J) = 27	
d H7 = 12	l1 = 10	
H = 65	l2 = 37	
H1 = 15	l3 = 40	
H2 = 20	r = 22	